

Introduction

Thank you for purchasing SoftBank 004Z wireless broadband modem.

- SoftBank 004Z is referred to as "modem" in this guide.
- Read this guide thoroughly beforehand for proper usage.
- Accessible services may be limited by contract conditions or service area.
- This modem is compatible with 3G network technologies.

Notes

- Unauthorized copying of any part of this guide is prohibited.
- Contents are subject to change without prior notice.
- Steps have been taken to ensure the accuracy of descriptions in this guide. If you find inaccurate or missing information, contact SoftBank Mobile Customer Center, General Information (P.7-3).

Chapter Contents At a Glance

Getting Started	1
Setup (Windows PC)	2
Windows Utility Operation Guide	3
Setup (Mac)	4
Mac Utility Operation Guide	5
Troubleshooting	6
Appendix	7

Contents

Contents.....	iii
Introduction.....	iv
Safety Precautions.....	v
General Notes.....	ix
Trademarks	x

1 Getting Started

Getting Started.....	1-2
Package Contents.....	1-2
Parts & Functions.....	1-2
USIM Card.....	1-3
SD Card	1-4

2 Setup (Windows PC)

Setup (Windows PC).....	2-2
Device Recognition (Windows PC)	2-2
Software Installation (Windows PC)	2-2
Device Removal (Windows PC).....	2-9

3 Windows Utility Operation Guide

SoftBank 004Z Utility Operations Guide (Windows PC)	3-2
Overview.....	3-2
Packet Communication Settings	3-3
Connecting/Disconnecting.....	3-4
Connection Record.....	3-5

4 Setup (Mac)

Setup (Mac).....	4-2
Device Recognition (Mac).....	4-2
Software Installation (Mac)	4-2
Device Removal (Mac).....	4-6

5 Mac Utility Operation Guide

SoftBank 004Z Utility Operations Guide (Mac)	5-2
Overview.....	5-2
Packet Communication Settings	5-3
Connecting/Disconnecting.....	5-4
Connection Record.....	5-5
Confirming Settings.....	5-6

6 Troubleshooting

Troubleshooting	6-2
-----------------------	-----

7 Appendix

Appendix	7-2
Specifications.....	7-2
Warranty & Service	7-2
Customer Service	7-3

Operating Environment

Use modem in any of these operating environments:

- **Compatible Operating Systems:**
 - Windows XP Home Edition (Service Pack 2 or later)
 - Windows XP Professional (Service Pack 2 or later)
 - Windows Vista Home Basic (32-bit or 64-bit)
 - Windows Vista Home Premium (32-bit or 64-bit)
 - Windows Vista Business (32-bit or 64-bit)
 - Windows Vista Ultimate (32-bit or 64-bit)
 - Windows 7 Starter Edition (32-bit)
 - Windows 7 Home Premium (32-bit or 64-bit)
 - Windows 7 Professional (32-bit or 64-bit)
 - Windows 7 Ultimate (32-bit or 64-bit)
 - Mac OS X 10.4 to 10.6 (Intel)Compatible OS includes both English and Japanese versions.
- **Memory Requirements:**
 - Windows XP: 256MB (512MB+ recommended)
 - Windows Vista: 512MB (1GB+ recommended)
 - Windows 7 (32-bit): 1GB+
 - Windows 7 (64-bit): 2GB+
 - Mac OS X: 256MB (512MB+ recommended)
- **Available Hard Disk Capacity:**
 - 50MB required (100MB+ recommended)
- **PC Interface:** USB 2.0

Use outside these environments may affect performance. Operating environment (hardware, connected peripherals, installed applications, etc.) may also affect performance.

- For PC support, OS version upgrade information, etc., see corresponding manufacturer's product support documentation.

Usage Conditions

- This modem is for use within SoftBank Mobile service areas/areas covered by SoftBank Mobile Global Roaming Service.
- Even within service area, transmissions may be disrupted inside buildings, aboard trains, inside tunnels, underground, behind buildings, in valleys, etc. Signal may be weak in some areas.
- Extremely strong or weak signals may disrupt transmissions.
- Modem transmissions are highly secure, however, eavesdropping can occur. Please use accordingly.
- This modem is a radio as stipulated by the Radio Law. Under this law, it must be submitted for inspection upon request.
- In public places please use modem without disturbing others.
- USIM Card must be installed for modem use.
- SoftBank Mobile is not liable for any damages/recovery costs associated with modem use.

Read Safety Precautions before using modem.



User Guide

- Read Safety Precautions before using modem.
- Observe precautions to avoid injury or property damage.
- SoftBank Mobile is not liable for any damages from modem use.

Safety Precautions

Labels





These labels indicate the degree of risk from improper use. Make sure you thoroughly understand meanings before reading on.

 DANGER	Great risk of death or serious injury ¹
 WARNING	Risk of death or serious injury ¹
 CAUTION	Risk of injury ² or damage to property ³

- 1 Includes blindness, wounds, low/high heat burns, electric shock, bone fractures, poisoning or other physical harm with aftereffects, or requiring hospitalization or ongoing hospital visits.
- 2 Includes wounds, burns, electric shock or other physical harm not requiring hospitalization or ongoing hospital visits.
- 3 Includes damage to home, furniture, livestock, pets, etc.

Symbols

These symbols indicate prohibited or compulsory actions. Make sure you thoroughly understand meanings before reading on.

 Prohibited	Prohibited actions
 Do Not Disassemble	Disassembly prohibited
 Avoid Liquids Or Moisture	Exposure to liquids prohibited
 Compulsory	Compulsory actions

Limitation of Liability

- SoftBank Mobile is not liable for any damages arising from natural disasters such as earthquakes, lightning, storms and floods, as well as fires through no fault of SoftBank Mobile, acts by third parties, other accidents, improper use by the user, whether intentionally or negligently, or use under other abnormal conditions.
- SoftBank Mobile is not liable for incidental damages arising out of the use or inability to use the product, including, but not limited to, corruption or loss of data, lost business revenue or suspension of business operations.
- SoftBank Mobile is not liable for any damages arising from improper use not conforming to the instructions in the instruction manuals.
- SoftBank Mobile is not liable for any damages arising from malfunctions caused by use in combination with connection equipment or software that is not authorized for use by SoftBank.
- SoftBank Mobile is not liable for any damages resulting from accidental loss/alteration of any downloaded data.
- SoftBank Mobile is not liable for corruption or loss of stored data resulting from failures or malfunctions of the product, regardless of the cause. Make sure to keep a separate memo of important data to limit damage caused by data corruption or loss to a minimum.

Device & USIM Card



Do Not
Disassemble

Do not disassemble, modify or solder device or related hardware.

May cause fire, injury, electric shock or malfunction.



Avoid Liquids
Or Moisture

Do not expose to liquids.

Do not leave device or related hardware wet after exposure to water, pet urine, etc., and do not insert wet device into PC. May cause overheating, electric shock, fire, injury or malfunction. Use them in an appropriate place properly.



Prohibited

Do not use or expose device or related hardware to extreme heat (e.g., near fire or sources of heat, in direct sunlight, inside vehicles, etc.).

May cause warping or malfunction. Device or related hardware may become hot and lead to burn injuries.



Prohibited

Do not place device in/on ovens, microwave ovens, pressure cookers, induction stoves or other cooking appliances.

May cause malfunction.



Compulsory

Stop using this device near gas stations or places with fire/explosion risk. Device use near petrochemicals or other flammables may cause fire/explosion.

Gases may ignite.

Using device near petrochemicals or other flammables may cause fire or explosion.



Prohibited

Do not apply strong shocks or impacts.

May cause malfunction.



Compulsory

If any unusual sounds, odors, smoke or other abnormalities occur while using or storing, turn off the PC connected with device.

Continued use may cause fire or electric shock.

CAUTION



Do not place device on unstable surfaces.

Device or related hardware may fall, resulting in injury, malfunction, etc.



Keep device out of infants' reach.

Infants may choke from swallowing device or related hardware or be injured, etc.



If your child is using device, explain all instructions and supervise usage.

Misuse may cause injury, etc.

Handling Device

WARNING



Power off nearby electronic devices employing high precision control systems or weak signals.

May cause electronic malfunctions, etc.

*Be especially careful near the following devices:

Devices that may be affected:

Hearing aids, implanted cardiac pacemakers, implanted defibrillators and other electronic medical equipment; fire alarms, automatic doors and other automatic control devices.



Because device radio waves may impair aircraft operations, please power off device while aboard.

When device use aboard aircraft is allowed, please follow instructions of airline personnel.



If thunder is heard while outdoors, turn power off; find cover.

There is a risk of lightning strike or electric shock.

CAUTION



If you experience any skin irritation associated with device use, discontinue device use and consult a doctor.

Metal and other materials may cause skin irritation, rashes, or itchiness depending on your physical condition.

	Parts	Material/Finishing
Main Unit	Unit	PC resin/UV coating
	Unit metal part	Stainless steel Beryllium bronze/gold coating
Package	External package	OPP bag



Keep this device away from magnetic cards, etc.

Data on bank cards, credit cards, telephone cards, floppy disks, etc. may be lost.



Device may become hot while in use, especially at high temperature.

Prolonged contact with skin may cause burn injuries.

Handling USIM Card & SD Card

CAUTION



Prohibited

Do not insert objects other than SD Card into SD Card Slot.

May cause overheating, electric shock or malfunction.



Prohibited

Do not shake, subject to shocks or remove SD Card while writing or reading SD Card data.

May cause data loss or malfunction.



Prohibited

Do not use SD Card other than the corresponding one.

May cause data loss or malfunction. Device supports SD Card with a storage capacity of up to 32 GB.



Prohibited

Do not use excessive force when inserting or removing USIM Card.

May cause malfunction. Be careful not to injure a hand or finger when removing USIM Card.



Prohibited

Do not use USIM Card other than specified one.

May cause data loss or malfunction.

Electronic Medical Equipment

CAUTION

This section is based on "Guidelines on Safeguarding Medical Equipment from Electromagnetic Waves from Mobile Phones and Other Devices" (Electromagnetic Compatibility Conference Japan), and "Research Report on the Influence of Electromagnetic Waves on Medical Equipment" (Association of Radio Industries and Businesses, March 2001).



Compulsory

Keep device a minimum of 22 centimeters from implanted cardiac pacemaker or implanted defibrillator.

Radio waves may interfere with implanted pacemakers or defibrillators.



Compulsory

If you intend to use electronic medical equipment other than implanted pacemaker/defibrillator outside medical facilities, consult the vendor on radio wave effects.

Radio waves may interfere with electronic medical equipment.



Compulsory

Observe the following in medical institutions. Radio waves from device may affect electronic medical equipment.

- Do not enter an operating room or an Intensive or Coronary Care Unit while carrying the device.
- Power off PC in hospitals.
- Even in lobbies or other places where device use is permitted, turn off the PC near electronic medical equipment.
- Obey medical facility rules on use.



Compulsory

Do not use in crowds/trains. People with implanted pacemaker/defibrillator may be near.

Radio waves may interfere with the operation of implanted cardiac pacemakers or implanted defibrillators.

Usage Basics

- Device transmissions may be disrupted inside buildings, tunnels, or underground, or when moving into/out of such places.
- Use device without disturbing others. Theaters and public transportation systems may or may not allow use of the device.
- Devices are radios as stipulated by the Radio Law. Under the Radio Law, devices must be submitted for inspection upon request.
- Files may be lost or damaged in the following situations. SoftBank Mobile is not liable for damages incurred due to lost or altered information. To minimize damages, back up data and store separately.
 - When using the device incorrectly.
 - When affected by static electricity or electrical noise.
 - When the power is turned Off while the device is operated.
 - When the device breaks down or is submitted for repair.
- The Ordinance of the Ministry Specifying Goods and Technologies Pursuant to Provisions of the Appended Table 1 of the Export Trade Control Order and the Appended Table of the Foreign Exchange Order documents might be needed depending on what kinds of devices are taken overseas, but if this device is taken abroad on trips or short business trips for personal usage, they essentially are not needed when bringing it back in. However, if this device is used by other individuals or handed over to them, an export license may be required. In addition, if the device is taken to countries (Cuba, North Korea, Iran, Sudan and Syria) which are subject to U.S. government stipulated export restraints, then U.S. government export licenses might be required. For details on the particulars of regulations for export laws and ordinances and procedures visit the Ministry of Economy, Trade and Industry's Security Export Control Division's website.
- Do not use this device in the proximity of areas where explosive materials are handled. An explosion may be induced. In addition, explosive devices might be affected.
- USIM Cards used by this device cannot be used with some models (includes models previously sold by SoftBank).

APN Settings

- The access point which corresponds to the predetermined flat-rate plan is configured by the device's utility software SoftBank 004Z Utility (factory default configuration). Appropriate access points conduct bandwidth controls via SoftBank's network.
- For contracted price plans besides the predetermined plans such as the Data Value Pack, use the below listed access point after additionally configuring the SoftBank 004Z Utility. When the following access point is used with a predetermined plan, corresponding transmissions are all charged on a pay-as-you-go basis, and since the billing might be expensive, please use the access point which corresponds to the predetermined plan that was configured in advance for the predetermined plan that is used.

Access point for pay-as-you-go plans such as the Data Value Pack
Access Internet
APN: softbank
ID: ai@softbank
Password: softbank

Aboard Aircraft

- Radio waves may impair aircraft operations; power off the device while aboard aircraft. If device use is allowed, follow the instructions of airline personnel.

Handling

- Do not expose device to rain, snow, or high humidity. This device is not waterproof. Avoid extreme temperatures/direct sunlight/dusty area.
- Avoid extreme temperatures/direct sunlight/dusty areas.
- Do not drop or subject device to shocks.
- USIM Cards used by this device cannot be used with some models (includes models previously sold by SoftBank).



microSD Logo is a trademark of SD-3C, LLC.



microSDHC Logo is a trademark of SD-3C, LLC.

Parts of this product protected under some or all of these United States Patents:

5,515,013	5,629,960	5,845,216	5,847,553	5,878,234
5,890,057	5,929,815	6,169,884	6,191,741	6,199,168
6,339,405	6,359,591	6,400,336	6,516,204	6,561,851
6,643,501	6,653,979	6,697,030	6,785,830	6,845,249
6,847,830	6,876,697	6,879,585	6,886,049	6,968,171
6,985,757	7,023,878	7,053,843	7,106,569	7,145,267
7,200,512	7,295,171	7,287,162	D442,170	D459,303
D599,256	D560,911			

Other patents pending.

Technology license is provided by QUALCOMM® 3G

Licensed by QUALCOMM Incorporated under one or more of the following United States Patents/their counterparts in other nations:

4,901,307	5,056,109	5,101,501	5,109,390	5,228,054
5,267,261	5,267,262	5,337,338	5,414,796	5,416,797
5,490,165	5,504,773	5,506,865	5,511,073	5,535,239
5,544,196	5,568,483	5,600,754	5,657,420	5,659,569
5,710,784	5,778,338			

ZTE, ZTE中興 and ZTE logo are trademarks or registered trademarks of ZTE Corporation in China/other countries.

Copyright © 2010 ZTE Corporation. All rights reserved.

SOFTBANK, SOFTBANK's equivalent in Japanese and the SOFTBANK logo are registered trademarks or trademarks of SOFTBANK CORP. in Japan and other countries.

Microsoft Windows Operating System is indicated in its abbreviated form as Windows.

Apple and "Apple" logos (Mac, Mac OS, Macintosh, QuickTime) are registered trademarks or trademarks of Apple Inc. in the United States/ other countries.

The names of the companies, products and services used in this guide are registered trademarks or trademarks of the respective companies.

Getting Started	1-2
Package Contents.....	1-2
Parts & Functions.....	1-2
USIM Card	1-3
SD Card	1-4

Package Contents

The following items are included in the package. Please confirm package contents before use. Contact SoftBank Mobile Customer Center, General Information (P.7-3) for missing items.

- 004Z

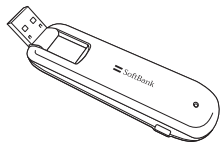

- Documentation



Quick Start Guide
(Japanese)

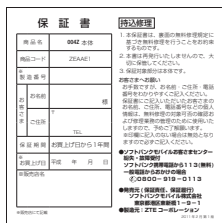

Warranty

- SoftBank 004Z is referred to as "modem" in this guide.
- This modem accepts microSD™/microSDHC™ Memory Card (sold separately). Purchase one to use SD Card functions.
- Keep Warranty in a safe place.

Parts & Functions

Part Names & Functions

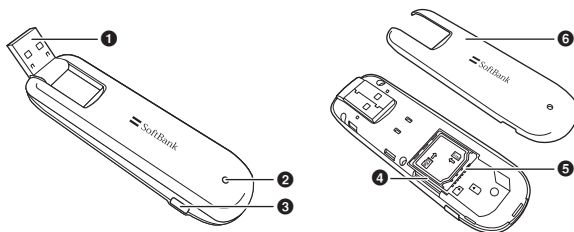

- ① USB Plug: Insert into PC USB port.
 - ② LED Status Lamp: Lights during transmissions.
 - ③ External Antenna Port: Attach External Antenna* here.
 - ④ SD Card Slot: Insert SD Card here.
 - ⑤ USIM Card Tray: To insert USIM Card.
 - ⑥ Cover: Remove to access USIM/SD Card Slot.
- *SoftBank Mobile does not offer nor support External Antenna.

LED Status Lamp

LED lamp shows communication status.

LED Status Lamp	Network Connection Status
Lights Red	Network not connected
Lights Green	2GB Network connecting
Flashes Green	2GB Network connected (data received)
Lights Blue	3GB Network connecting
Flashes Blue	3GB Network connected (data received)

USIM Card

USIM Card is the property of SoftBank Mobile. The IC chip contains customer information including phone number. USIM Card must be installed for use. For details, see USIM Card guide (Japanese). Do not remove USIM Card while in use; may damage card/device. If USIM Card comes loose, follow steps below:

- 1 Close SoftBank 004Z Utility
- 2 Remove modem from PC
- 3 Insert USIM Card
- 4 Reinsert modem into PC

USIM Card Installation

- 1 Remove Cover
- 2 Insert USIM Card into USIM Card Tray with IC chip down
- 3 Confirm USIM Card installation and replace Cover

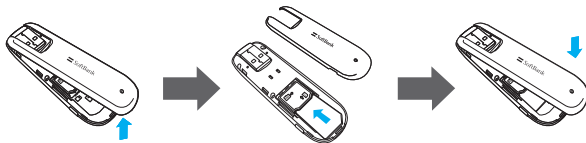

Removing USIM Card

- 1 Remove Cover
- 2 Remove USIM Card
- 3 Replace Cover

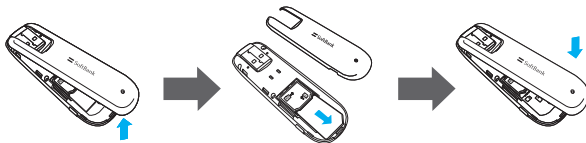

- Do not apply excessive force when inserting/removing USIM Card; may cause injury or damage card/modem.
- Do not misplace removed USIM Card. Keep it away from infants to avoid injury (swallowing hazard)/damage.
- If USIM Card IC chip is dusty, clean with a soft cloth.

SD Card

004Z accepts SD Card (microSD or microSDHC) up to 32GB. SoftBank Mobile does not guarantee compatibility with any specific software. Install SD Card to use SD Card functions. Do not remove SD Card while in use; may cause data loss/malfunction. If SD Card comes loose, follow these steps:

- 1 Close SoftBank 004Z Utility
- 2 Remove modem from PC
- 3 Insert SD Card into modem
- 4 Reinsert modem into PC

SD Card Installation

- 1 Remove Cover
- 2 Insert SD Card with contacts up
- 3 Replace Cover

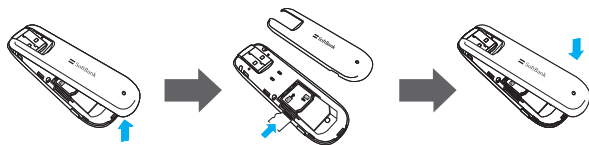

Removing SD Card

- 1 Remove Cover
- 2 Push SD Card lightly until it clicks; when it pops out, remove it
- 3 Replace Cover

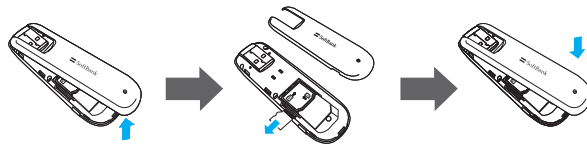

- Do not insert USIM Card or SD Card with excessive force. May cause damage. Do not misplace a removed SD Card.

Setup (Windows PC)	2-2
Device Recognition (Windows PC)	2-2
Software Installation (Windows PC)	2-2
Device Removal (Windows PC)	2-9

Device Recognition (Windows PC)

With USIM Card installed, insert modem USB plug into PC USB port. PC should automatically recognize modem within approximately 45 seconds.

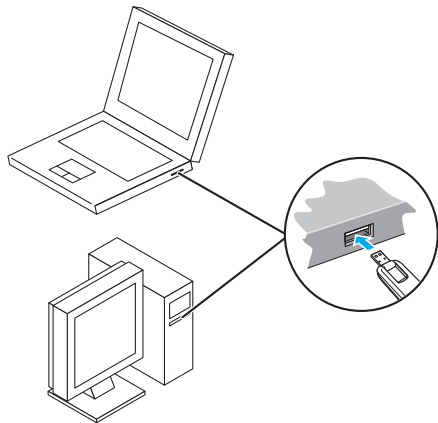

System message appears upon modem recognition. See "Software Installation (Windows PC)" to install SoftBank 004Z Utility.

- Modem may fail if PC enters sleep mode, etc. with it connected. Remove modem before leaving a PC unattended, etc. Modem may malfunction if connected before PC starts/restarts. Remove modem before starting or restarting PC.

Software Installation (Windows PC)

Use this modem to access Network or adjust settings. All screenshots and procedures based on Windows 7.

Installing SoftBank 004Z Utility

- Do not remove modem during installation. May cause installation failure, system malfunction or other system errors.
- Login using administrator privilege.

- 1** Power on PC and initiate Windows
- 2** Insert modem into PC
- 3** Utility installer and device driver are stored on modem. Modem installs as USB mass-storage device at first use. (Device recognition takes approximately 45 seconds.) Utility installer starts, device driver and utility software install automatically

- If an older version of SoftBank 004Z Utility is already installed a message appears. Remove old version before installation (See "Uninstalling SoftBank 004Z Utility" on P.2-8.).

4 "AutoPlay" dialog box appears. Click "Run AutoRun.exe"

For Windows XP, "AutoPlay" does not appear.

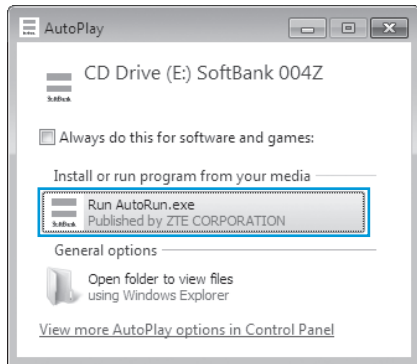
**5 "User Account Control" dialog box appears. Click "Yes"**

For Windows Vista, click "Continue."

6 Installer starts automatically

"設定言語の選択" (Language Setting) dialog box appears.

Select "英語" (English) and click "OK."

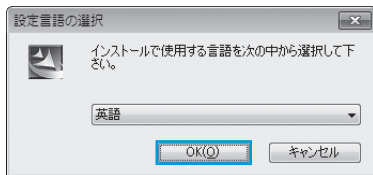

- PC recognizes modem in about 45 seconds upon connection.
- For manual installation, see P.2-5,P.2-6, and P.2-7.

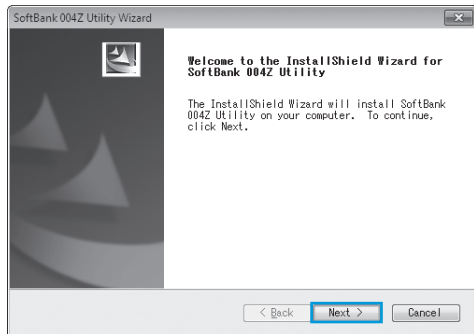
7 "Welcome to the InstallShield Wizard for SoftBank 004Z Utility" dialog box appears. Click "Next"

8 "License Agreement" appears

If agreed, click "I accept the terms of the license agreement" and click "Next."

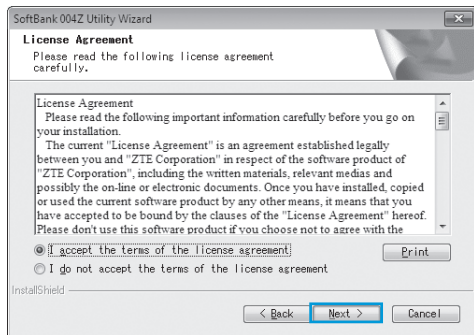
**9 "Choose Destination Location" dialog box appears**

Specify a folder and click "Next."

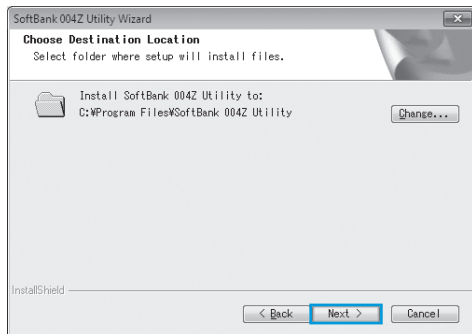

10 When dialog box below appears, click "Finish"

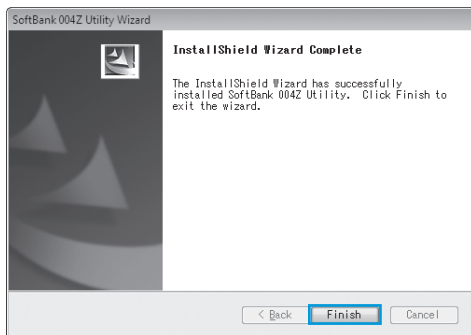

11 SoftBank 004Z Utility shortcut icon appears on desktop

- Restart PC if it does not function correctly.

Manual Installation* (Windows 7)

If installer fails to start automatically, follow these steps:
*Always power on PC before inserting modem USB plug.

1 In Start Menu, click "Computer"

2 Double click "SoftBank 004Z"

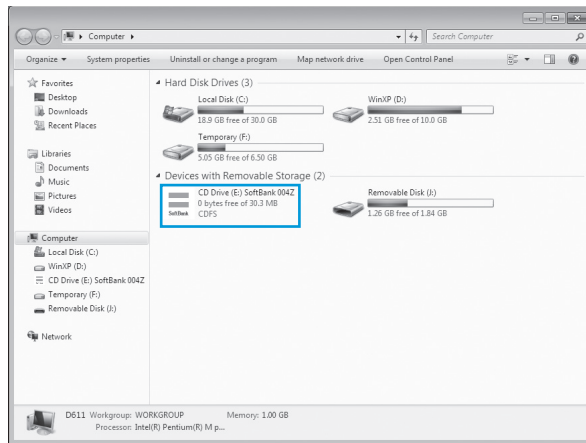

3 "User Account Control" dialog box appears. Click "Yes"

2

Setup (Windows PC)

4 Select language and click "OK"

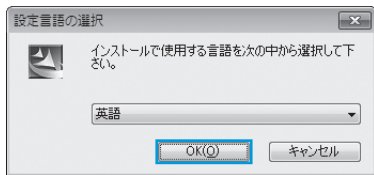

5 "Welcome to the InstallShield Wizard for SoftBank 004Z Utility" dialog box appears. Skip to Step 7 on P.2-3

Manual Installation* (Windows Vista)

If installer fails to start automatically, follow these steps:
*Always power on PC before inserting modem USB plug.

1 In Start Menu, click "Computer"

2 Double click "SoftBank 004Z"

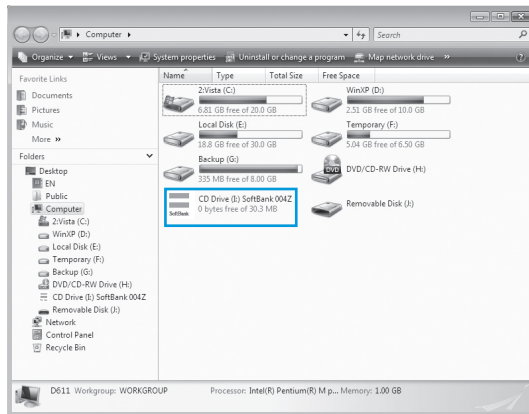

3 "User Account Control" dialog box appears. Click "Continue"

4 Select language and click "OK"

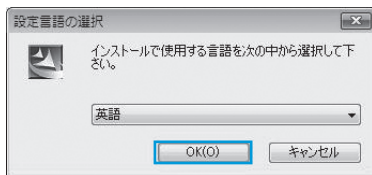

5 "Welcome to the InstallShield Wizard for SoftBank 004Z Utility" dialog box appears. Skip to Step 7 on P.2-3

Manual Installation* (Windows XP)

If installer fails to start automatically, follow these steps:
*Always power on PC before inserting modem USB plug.

1 In Start Menu, click "Computer"

2 Double click "SoftBank 004Z"

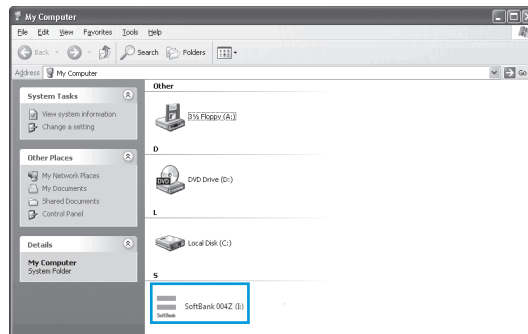

- 3 Select language and click "OK"

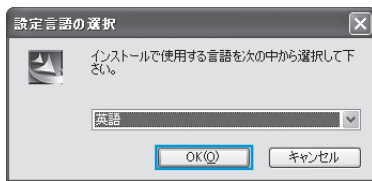

- 4 "Welcome to the InstallShield Wizard for SoftBank 004Z Utility" dialog box appears. Skip to Step 7 on P.2-3

Uninstalling SoftBank 004Z Utility

- 1 Select "Start" → "All Programs" → "SoftBank 004 Utility" → "Uninstall"
- 2 "User Account Control" appears. Click "Yes"
For Windows Vista, click "Continue."
- 3 "Do you want to completely remove the selected application and all of its features?" confirmation appears. Click "Yes"
- 4 "Please remove USB MODEM from PC, before uninstalling!" confirmation appears. Click "Yes" to start installation

- 5 Upon uninstallation, dialog box below appears. Click "Finish" to end uninstallation

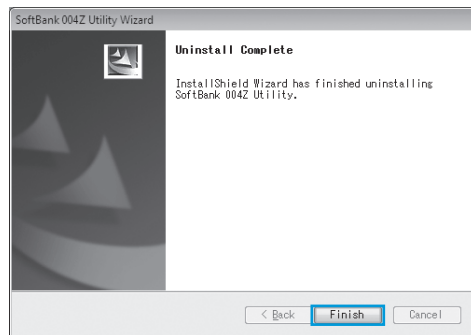

Device Removal (Windows PC)

- Close SoftBank 004Z Utility before removing modem. Do not remove modem during transmissions.

For Windows 7, exit Utility before removing modem.

- With SD Card installed, in Task Tray, click  then click "Eject Removable Disk." Once modem can be removed safely, remove it.

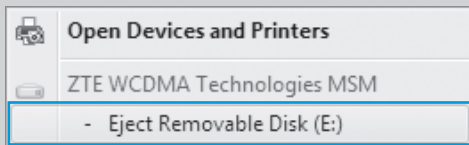

For Windows Vista/Windows XP, click "Removable Disk" before removing modem.

1 Double click on Task Tray

For Windows XP, double click  in Task Tray.

2 "Safely Remove Hardware" appears. Select "USB Mass Storage Device" and click "Stop"

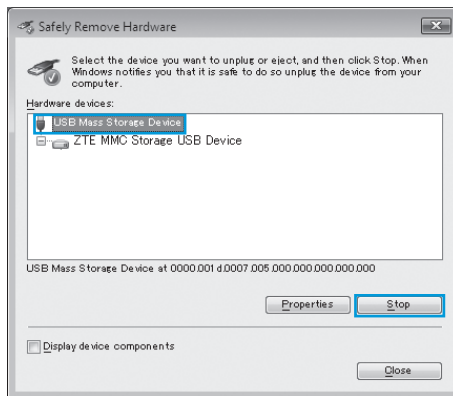

2

Setup (Windows PC)

- 3 "Stop a Hardware device" appears. If modem can be safely removed from PC, click "OK"

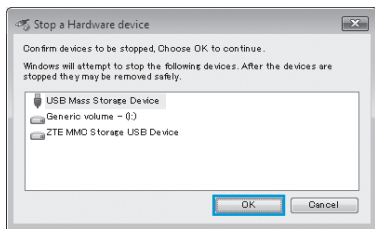

- For Windows XP, "USB Mass Storage Device" appears.
- 4 Return to "Safely Remove Hardware" dialog box. Repeat steps for "USB Mass Storage Device"
- For Windows XP, "USB Mass Storage Device" appears.

- 5 Once modem can be removed safely, remove modem

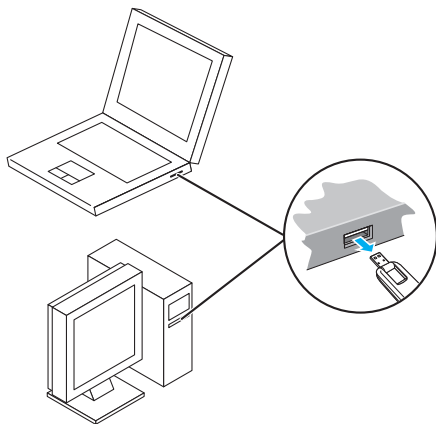

- After executing "Stop Hardware Device," LED Status Lamp may light or flash. This is normal. Remove modem from PC.

SoftBank 004Z Utility Operations Guide (Windows PC)	3-2
Overview	3-2
Packet Communication Settings.....	3-3
Connecting/Disconnecting.....	3-4
Connection Record.....	3-5

Overview

Initiating SoftBank 004Z Utility

To activate SoftBank 004Z Utility, double-click  (SoftBank 004Z Utility shortcut). For Windows 7 or Windows Vista, insert modem to automatically open "AutoPlay" dialog box. Click "Run AutoRun.exe" to initiate SoftBank 004Z Utility.



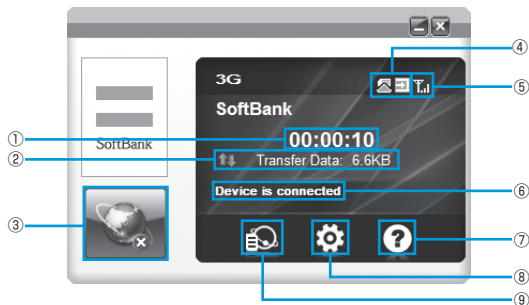

For Windows XP, insert modem plug into PC USB port to automatically initiate SoftBank 004Z Utility.

Main Screen



- 1 Connection Time**
Changing PC clock during connections affects accuracy.
- 2 Transferred Data Meter**
- 3 Connect/Disconnect**
- 4 Connection Indicators**
USIM Card connection status
- 5 Signal Strength Indicator**
- 6 Network Connection Status**
- 7 Help**
Open User Guide PDF file (Japanese)
- 8 Configuration**
Perform activation settings or profile settings.
- 9 Communication Record**
Open connection record.

Signal Strength Window

Icon	Signal Strength
	Out-of-range
	Faint
	Weak
	Medium
	Strong

Packet Communication Settings

Dial-up profile must be set up for packet communications. In Main Screen, click  for Connection dialog box.

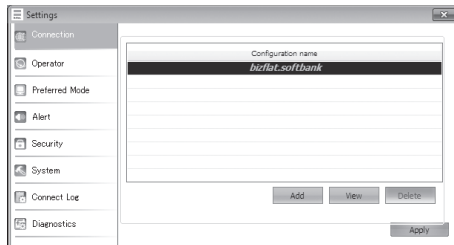

SoftBank 004Z Utility Connection dialog box appears.

Creating New Profile

1 Click "Add"

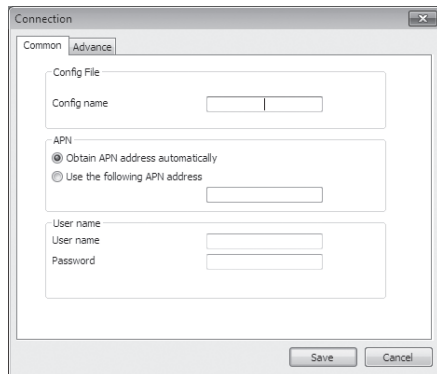

2 Set Config name, APN, User name, and Password

- As required, click "Advance" tab to set DNS, PDP Server, Authentication Mode, or PDF types.

3 Click "Save" to save all dial-up connecting destination settings, and close dialog box

- Click "Cancel" to close Connection dialog box.

Editing Profile

- 1 Select profile to edit from "Configuration name" list
- 2 Click "Edit" to change set information
- 3 Click "Save" to save reset information
- 4 Click "Apply" to save setting
 - Close window to exit dial-up connecting destination setting.

Deleting Profile

- 1 Select profile to delete from "Configuration name" list
- 2 Click "Delete" to open confirmation dialog box
- 3 Click "OK" to delete selected profile
 - Click "Cancel" to keep selected profile.
- 4 Click "Apply" to save setting
 - Close window to exit dial-up connecting destination setting.

Connecting/Disconnecting

Starting

- 1 Click  to initiate connection



During connections, confirm connection time, transmitted, and received data size of the current connection here.

Disconnecting

- 1 Click  to end connection



Connection Record

- Changing PC clock during connections affects record accuracy.

Communication Record

- 1 Click  for data record
- If "Data usage is approximate only, please contact your operator for actual usage" confirmation appears, click "OK."

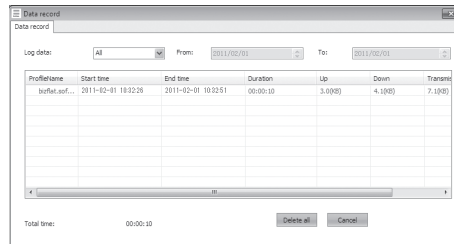

Checking Communication Summary

- 1 Click "From"/"To" for statistics

Data record

Log data: period: From: 2011/02/01 To: 2011/02/01

ProfileName	Start time	End time	Duration	Up	Down	Transmits
buffer.suf...	2011-02-01 10:02:26	2011-02-01 10:02:51	00:00:25	3,0980	4,1000	7,1980

Total time: 00:00:00

Buttons: Delete all, Cancel

- This is only a guide. Actual transmissions may differ.

Setting Operator

- 1 In Main Screen, click
- 2 Click "Operator" to select "Automatic" or "Manual"
 - Select "Manual" and click "Search" to find operator.

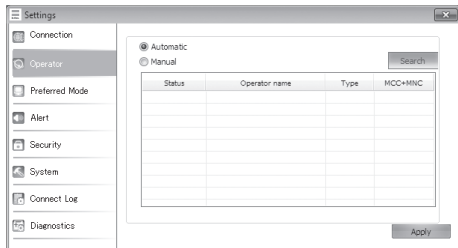

- 3 Click "Apply" to save setting

Preferred Network

- 1 In Main Screen, click
- 2 Click "Preferred Mode" to select "Automatic" or "3G only" or "GSM only"

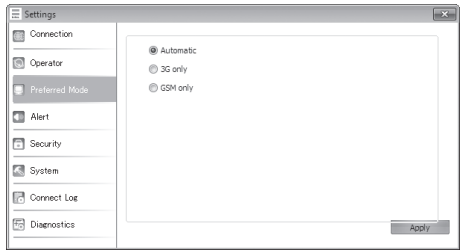

- 3 Click "Apply" to save setting
- Preferred Network is selectable only if Operator Selection is set to "Automatic."

Alert

- 1 In Main Screen, click
- 2 Click "Alert" to select "Network connect alert"/"Network disconnect alert"
 - Click "Browse" to select files on PC.
 - If "Mute" is checked, sound cannot be set.

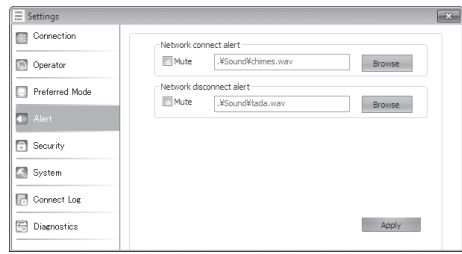

- 3 Click "Apply" to save setting

Security Code

PIN

Personal Identification Number (PIN) is USIM Card security code. Change PIN, or activate/cancel PIN Authentication to control USIM Card access.

Default: PIN Authentication is off/PIN is "9999"

PIN Authentication

Activate or cancel PIN Authentication. When active, PIN entry is required for modem use.

- In Main Screen, click  → "Security" → Check/Uncheck Box → "Apply." PIN entry window appears. Enter new PIN, and click "OK."

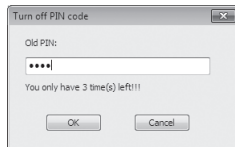
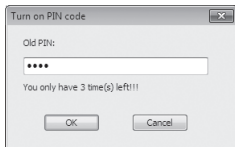

Changing PIN

- 1 In Main Screen, click  → Click "Security" → Click "Revise PIN" (checked)
- 2 If "Security" window appears, enter current PIN and new PIN
- 3 Enter new PIN again
- 4 Click "OK" to complete change

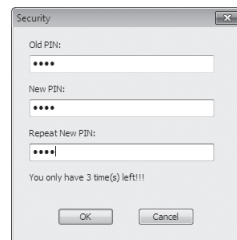

- Set four- to eight-digit number as PIN.
Default: 9999

Entering PIN

If PIN Authentication is active, PIN entry is required for modem use.

- 1 Insert modem USB plug into PC USB port, and activate SoftBank 004Z Utility for PIN entry window
- 2 Enter PIN correctly
- 3 Click "OK" for authentication

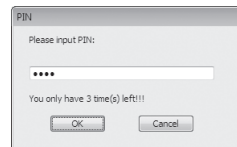

Unlocking PIN

- 1 If USIM Card is locked, PUK Code entry window appears
- 2 Enter PUK Code correctly
- 3 Set new PIN
- 4 Enter new PIN again
- 5 Click "OK" to complete change

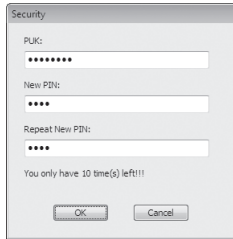

- Incorrectly entering PIN three consecutive times activates PIN Lock. PUK Code is required to unlock it. Entering PUK Code ten consecutive times locks modem completely. If modem is completely locked, predefined procedures are required. Contact SoftBank Mobile Customer Center, General Information (P.7-3).

System Settings

- 1 In Main Screen, click
- 2 Click "System" to select "Startup"/"Auto connect"
 - If "Auto connect" is checked, connection starts automatically.

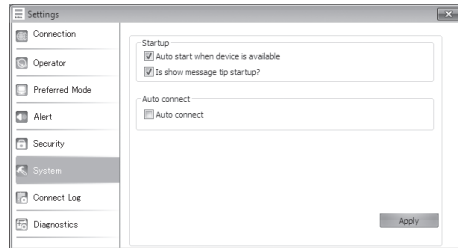

- 3 Click "Apply" to save setting

Connect Log Setting

- 1 In Main Screen, click 
- 2 Click "Connect Log" for "Set price"/"Set connect unit"
 - If "Set connect unit" is checked, "Byte"/"Packet" is selectable.

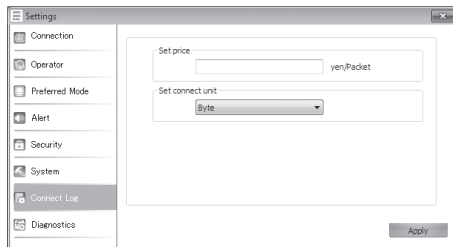

- 3 Click "Apply" to save setting

Viewing Diagnostics

- 1 In Main Screen, click 
- 2 Click "Diagnostics" to view "Software information" (Version Information) and "Device information" (Device name/IMEI/Phone number)
 - Click "Refresh" to update information.

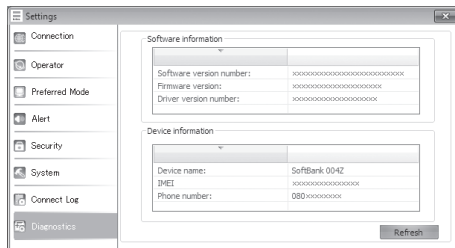

Setup (Mac)	4-2
Device Recognition (Mac)	4-2
Software Installation (Mac)	4-2
Device Removal (Mac).....	4-6

Device Recognition (Mac)

With USIM Card installed, insert modem USB plug into Mac USB port. Mac should automatically recognize modem within approximately 45 seconds.

4

Setup (Mac)

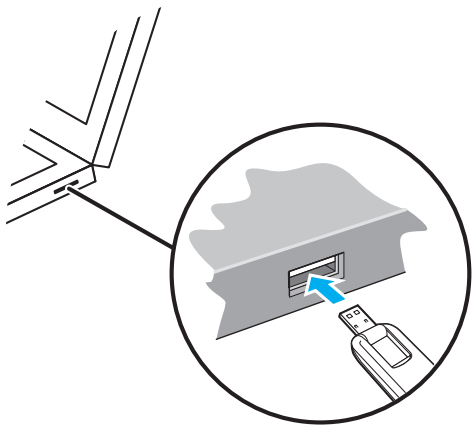

System message appears upon modem recognition. See "Software Installation (Mac)" to install SoftBank 004Z Utility.

- Modem may fail if Mac enters sleep mode, etc. with it connected. Remove modem before leaving a Mac unattended, etc. Modem may malfunction if connected before Mac starts/ restarts. Remove modem before starting or restarting Mac.

Software Installation (Mac)

Installing SoftBank 004Z Utility

Use this modem to access Network or adjust settings. All screenshots and procedures based on Mac OS 10.6.

- Do not remove modem during installation. May cause installation failure, system malfunction or other system errors.

1 Power on Mac and initiate Mac

2 Insert modem into Mac

If  icon appears on desktop, double click it. "SoftBank 004Z Utility.mpkg" folder opens automatically.

- 3** Double click "SoftBank 004Z Utility.mpkg" folder to start installation. Dialog box below appears. Click "Continue"

- If an older ZTE Utility is already installed, uninstall it first.
- Make sure that only the latest Utility is installed before use.

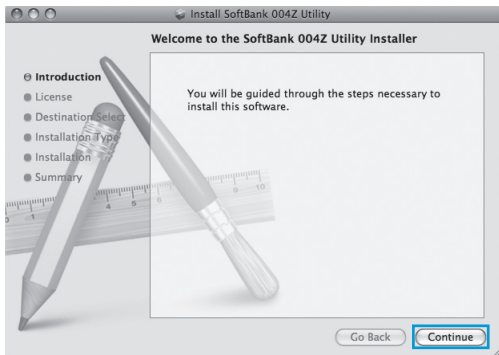

- 4** "Software License Agreement" appears. Click "Continue"

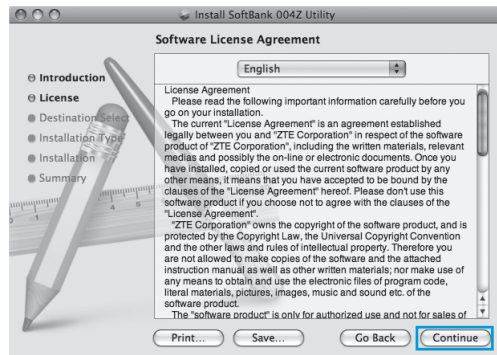

- 5** If agreed, click "Agree"

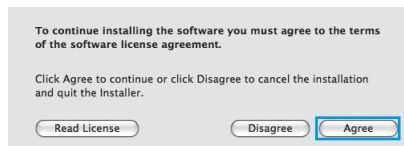

If "Select a Destination" appears, select target folder and click "Continue."

- 6 "Standard Install on "Macintosh HD"" dialog box appears. Click "Install"

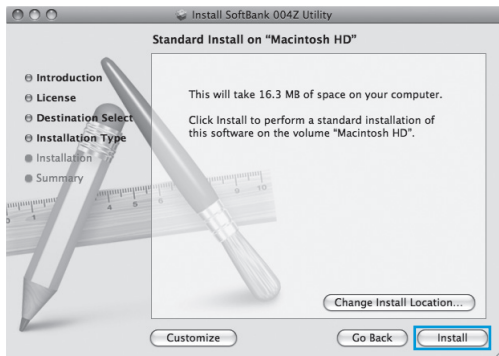

- "Macintosh HD" is hard disk name. It may vary.

- 7 "Certification" appears. Enter User Name and Password and click "OK"



- 8 Installation starts

9 When dialog box below appears, click "Close"

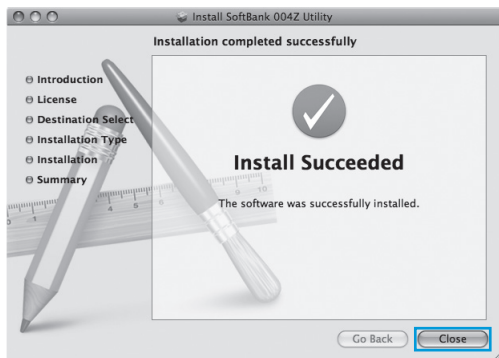

10 SoftBank 004Z Utility starts automatically

- Restart Mac if it does not function correctly.

Uninstalling SoftBank 004Z Utility

- 1 Click  to open Finder
- 2 Delete SoftBank 004Z Utility
 - Drag Uninstall SoftBank004Z.app file from /Macintosh HD/ Applications folder into trash bin.
- 3 Delete driver
 - Drag ZTEUSB CDCACMData.kext file from /Macintosh HD/ System/Library/Extensions folder into trash bin.
 - Drag ZTEUSBMassStorageFilter.kext file from /Macintosh HD/ System/Library/Extensions into trash bin.
- 4 Delete ModemList
 - Drag /Macintosh HD/System/Library/ModemList folder into trash bin.
- 5 Delete Modem Scripts
 - Drag ZTE USB MODEM file from /Macintosh HD/Library/ Modem Scripts folder into trash bin.
- 6 Delete Installer
 - Drag ZTE folder from /Macintosh HD/Library/Application Support folder into trash bin.
 - Drag cn.com.zte.usbswapper.plist file from /Macintosh HD/ Library/LaunchAgents folder into trash bin.
 - Drag cn.com.zte.PPPMonitor.plist file from /Macintosh HD/ Library/LaunchDaemons folder into trash bin.
- 7 Restart Mac

- "Macintosh HD" is hard disk name. It may vary.

Device Removal (Mac)

- Close SoftBank 004Z Utility before removing modem. Do not remove modem during transmissions.

4

Follow the steps below to remove modem from Mac. Modem may be damaged if it is improperly removed.

1 Click  to open Finder

2 In Finder, click  beside "SoftBank 004Z"

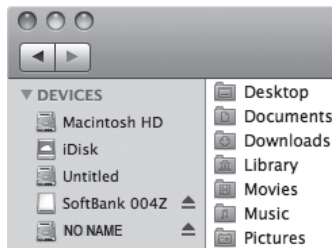

- If SD Card is installed, first click  card removal icon, then click  beside "SoftBank 004Z."

3 Remove modem from Mac

In Finder, if the above icon does not appear, end SoftBank 004Z Utility and remove modem.

SoftBank 004Z Utility Operations Guide (Mac)	5-2
Overview.....	5-2
Packet Communication Settings.....	5-3
Connecting/Disconnecting.....	5-4
Connection Record.....	5-5
Confirming Settings	5-6

Overview

Initiating SoftBank 004Z Utility

Insert modem USB plug into Mac USB port. SoftBank 004Z Utility activates automatically.

- If SoftBank 004Z Utility does not activate automatically, double click "Macintosh HD" → "Applications" → "SoftBank 004Z Utility."
- "Macintosh HD" is hard disk name. It may vary.

Main Screen of SoftBank 004Z Utility

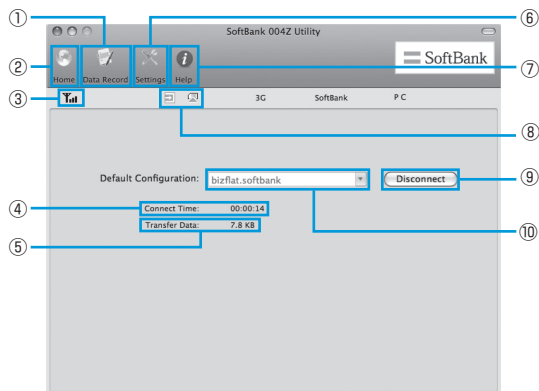

- ① **Communication Record**
Open connection record.
- ② **Home**
Return to Main Screen.
- ③ **Signal Strength Indicator**
See P.3-2 for the description of Signal Strength Icons
- ④ **Connection Time**
Changing Mac clock during connections affects accuracy.
- ⑤ **Transferred Data Meter**
- ⑥ **Network Connection Status**
- ⑦ **Help**
Open User Guide PDF file (Japanese)
- ⑧ **Connection Indicators**
USIM Card connection status
- ⑨ **Connect/Disconnect**
- ⑩ **Access Point**
Show dial-up connection.

Packet Communication Settings

Dial-up profile must be set up for packet communications.

Creating New Profile

- 1 In Main Screen, from "Default Configuration" pull down menu, select "Edit Configuration"
- 2 Click **+** to add new profile

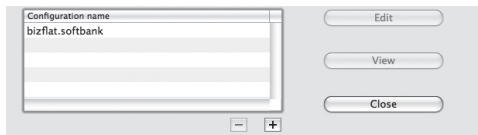

- 3 Select added profile and click "Edit"
- 4 Set Config name, Address, User name and Password
 - As required, settings for DNS, PDP Server, are available.
- 5 Click "OK" to save all dial-up connecting destinations settings, and close dialog box
 - Click "Cancel" to close Connection dialog box.
- 6 Click "Close" to return to Main Screen

Editing Profile

- 1 Select profile to edit from "Configuration name" list
- 2 Click "Edit" to change set information
- 3 Click "OK" to save reset information
- 4 Click "Close" to return to Main Screen

Deleting Profile

- 1 Select profile to delete from "Configuration name" list
- 2 Click **-** to open confirmation dialog box
- 3 Click "OK" to delete selected profile
 - Click "Cancel" to keep selected profile.
- 4 Click "Close" to return to Main Screen

Connecting/Disconnecting

Starting

- 1 Click "Connect" to initiate connection

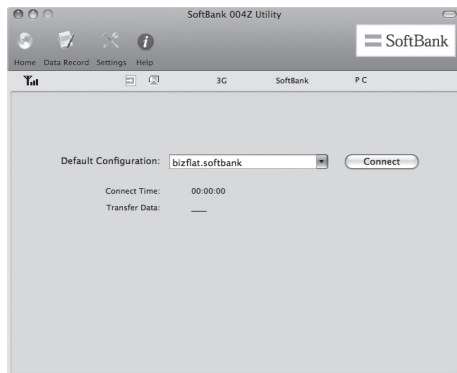

During connections, confirm connection time, transmitted, and received data size of the current connection here.

Disconnecting

- 1 Click "Disconnect" to end connection

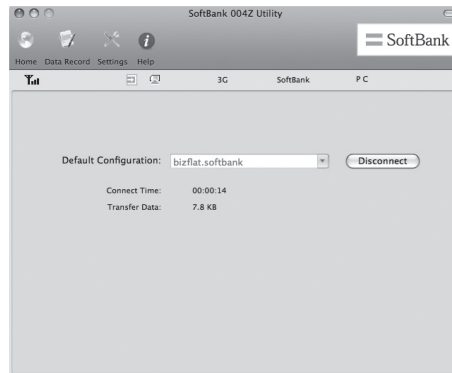

Connection Record



- Changing Mac clock during connections affects record accuracy.

Communication Record

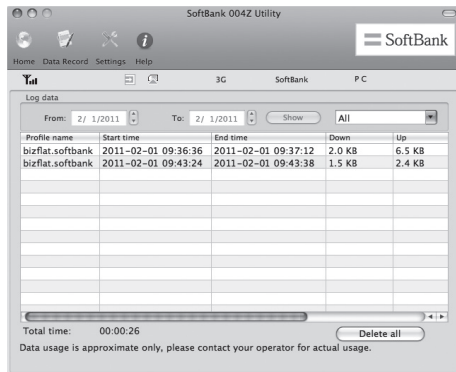
- 1 Click "Data Record" for data record



Checking Communication Summary

- 1 Click  to set "Period"
- If "Period" is selected, statistical period is selectable in "From"/"To" field. Click  to adjust time and date. Click "Show" for data statistics.

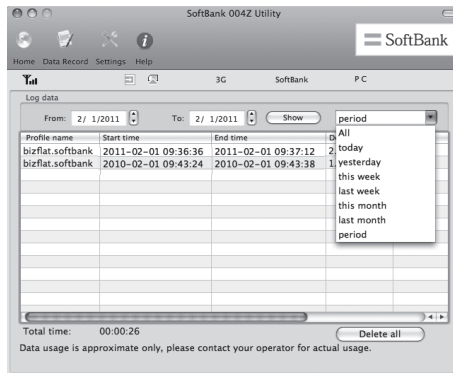

- This is only a guide. Actual transmissions may differ.

Confirming Settings

Preferred Network

- 1 In Main Screen, click "Settings"
- 2 Click "Network" to set Operator Selection to "Automatic" or "Manual"
 - If Operator Selection is set to "Automatic," modem searches for preferred network automatically. Preferred Network is selectable only if Operator Selection is set to "Automatic."

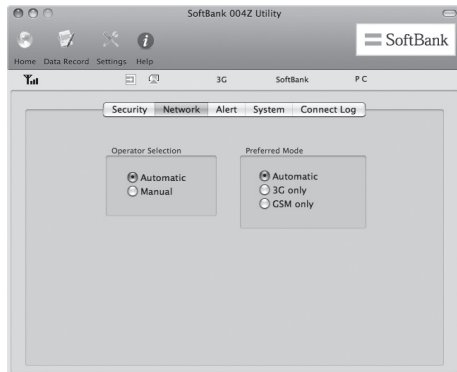

Alert

- 1 In Main Screen, click "Settings"
- 2 Click "Alert" to select "Network connect alert" or "Network disconnect alert"
 - Click "Browse" to select files on Mac.
 - If "Mute" is checked, sound cannot be set.

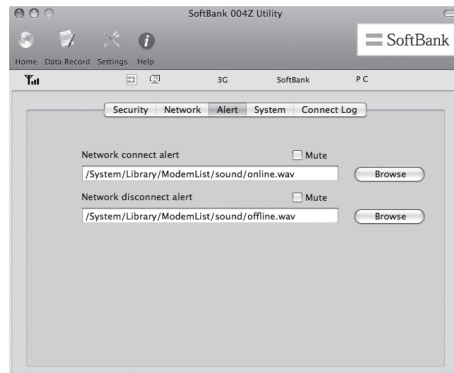

Security Code

PIN

Personal Identification Number (PIN) is USIM Card security code. Change PIN, or activate/cancel PIN Authentication to control USIM Card access.

Default: PIN Authentication is off/PIN is "9999"

PIN Authentication

Activate or cancel PIN Authentication. When active, PIN entry is required for modem use.

- In Main Screen, click "Settings" → "Security" → Check/Uncheck Box for PIN entry window.

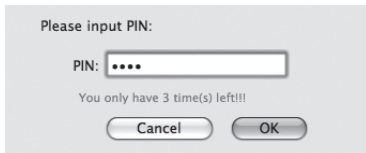

Changing PIN

- 1 Click "Settings" → "Security" → "Revise PIN" (checked)
- 2 If Change PIN window appears, enter current PIN and new PIN
- 3 Enter new PIN again

- 4 Click "OK" to complete change



- Set four-to eight-digit number as PIN.
Default: 9999

Entering PIN

If PIN Authentication is active, PIN entry is required for modem use

- 1 Insert modem USB plug into Mac USB port, and activate SoftBank 004Z Utility for PIN entry window
- 2 Enter PIN correctly
- 3 Click "OK" for authentication

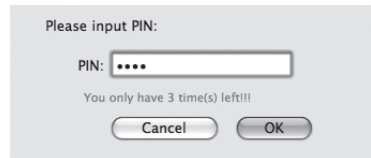

Unlocking PIN

- 1 If USIM Card is locked, PUK Code entry window appears
- 2 Enter PUK Code correctly
- 3 Set new PIN
- 4 Enter new PIN again
- 5 Click "OK" to complete change

Please input:

PUK:

New PIN:

Repeat New PIN:

You only have 10 time(s) left!!!

Cancel OK

- Incorrectly entering PIN three consecutive times activates PIN Lock. PUK Code is required to unlock it. Entering PUK Code ten consecutive times locks modem completely. If modem is completely locked, predefined procedures are required. Contact SoftBank Mobile Customer Center, General Information (P.7-3).

System Settings

- 1 In Main Screen, click "Settings"
- 2 Click "System" to set "Automatic" and "Select Language"
 - In "Automatic" field, check item to set.
 - In "Select Language" field, select "日本語" or "English."

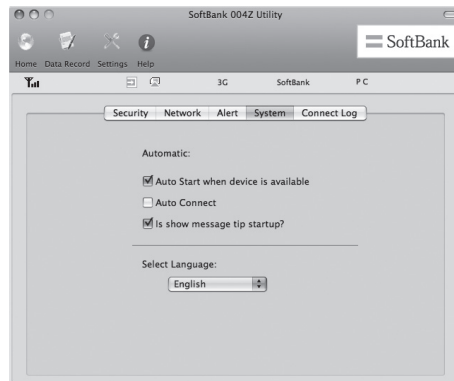

Connection Log Setting

- 1 In Main Screen, click "Settings"
- 2 Click "Connect Log" to set "Set price" / "Set connect unit"
 - If "Set Connect unit" is checked, "Byte" / "Packet" is selectable.
- 3 Click "Apply" to save setting

Troubleshooting	6-2
-----------------------	-----

1. PC does not recognize modem	P.6-2
2. Inserting modem does not automatically activate installer	P.6-3
3. Failed Internet connection	P.6-3
4. Transmission fails	P.6-4
5. Communication speed is slow	P.6-4
6. Forgot PIN/Unknown PUK Code/USIM Card is locked	P.6-4
7. USIM Card is not recognized	P.6-4
8. Unsure whether logged in as Administrator	P.6-5
9. Error Messages	P.6-5

1. PC does not recognize modem

- 1 Check whether modem is properly inserted in PC
- 2 Remove modem from PC, restart PC, then reinsert modem
 - For Windows 7 or Windows Vista, follow these steps to confirm proper modem installation.
 - 1 Right click "Computer" and select "Property." Click "System settings" for "User account control," then click "Yes" (Windows 7). For Windows Vista, click "Continue"
 - 2 When "System properties" appears, select "Hardware" tab, then click "Device manager"

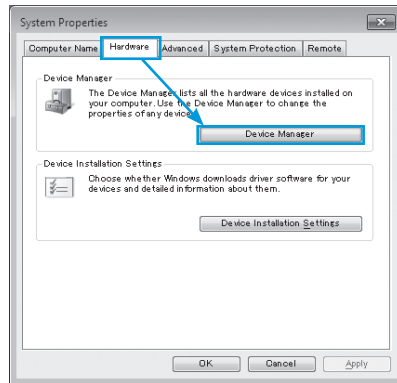

- If using Windows XP, right click "My computer," then select "Property."
- "System properties" appears. Select "Hardware" tab, then click "Device manager."

- 3 Confirm that devices outlined in the rectangles appear. (COM port numbers differ by PC operating environment.)

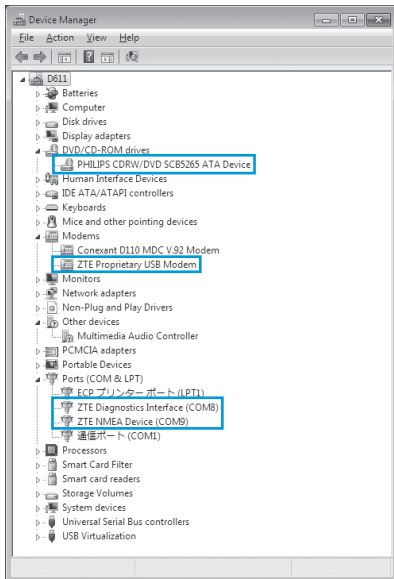

- For Mac, follow these steps to confirm modem installation:

- 1 Click  to open terminal dialog box
- 2 Input "ls/dev/cu" command*
- 3 Confirm that the information below appears:

```
/dev/cu.ZTEUSBModem_  
/dev/cu.ZTEUSBATPort_  
/dev/cu.ZTEUSB DIAGPort_
```

2. Inserting modem does not automatically activate installer

New hardware recognition takes about 45 seconds. If installer does not automatically activate, remove modem from PC, then restart PC. If installer does not activate automatically, see P.2-5, P.2-6 or P.2-7.

3. Failed Internet connection

Make sure you are within the service area.

- If signal reception is poor, move to where signal is strong, then reconnect.
- The access point might be busy depending on the time of day, wait a little while then reconnect.
 - For Windows, follow these steps to confirm network settings:
 - 1 In Main Screen, click 
 - 2 Click "Access point"
 - 3 Click "Display" and confirm settings

- For Mac, follow these steps to confirm modem installation:
 - 1 In Main Screen, select "Change" from "Default" pulldown menu
 - 2 Select the access point
 - 3 Click "Display" and confirm settings

4. Transmission fails

- 1 Check whether modem is properly connected to PC
- 2 Signal may be weak. Move to where signal is stronger
- 3 Remove modem from PC and reconnect
- 4 If Steps 1 to 3 do not re-establish a connection, remove modem and restart PC, then try again

5. Communication speed is slow

Signal may be weak. Move to where signal is stronger. Connection may be poor. Try again later.

6. Forgot PIN/Unknown PUK Code/USIM Card is locked

Contact SoftBank Mobile Customer Center, General Information (P.7-3).

7. USIM Card is not recognized

- 1 Confirm that USIM Card is properly installed. For details, see P.1-3 "USIM Card Installation"
- 2 Check for bent USIM Card
- 3 Check USIM Card IC chip for scuffs/corrosion
- 4 Debris on USIM Card IC chip may prevent recognition. Clean it with a soft cloth
- 5 Contact SoftBank Mobile Customer Center, General Information (P.7-3)

8. Unsure whether logged in as Administrator

- For Windows 7 or Windows Vista
 - 1 Click Start menu → "Control Panel" for "Control Panel" window
 - 2 Click "User Accounts and Family Safety" then click "User Accounts" in the next window
 - 3 User name and account type appear on the right. If "Administrator" appears, set up modem
- For Windows XP
 - 1 Click "Start" for "Start" menu
 - 2 Currently logged-in user name appears at top of "Start" menu
 - If "Start" menu display is set to Classic "Start," user name does not appear. Right click "Start" menu → Select Properties → Select "Start" menu radio button.
 - 3 Click "Start" → "Control Panel" for "Control Panel" window
 - 4 Click "User Accounts"
 - 5 Check user name in Step 2. If "Computer administrator" appears below user name, modem can be set up

9. Error Messages

Error Message	Descriptions/Solution
Limited Service	Network is restricted. Contact SoftBank Mobile Customer Center, General Information (P.7-3).
Incorrect (U)SIM Card	Is incorrect USIM Card installed? Install correct USIM Card.
No Service	Modem cannot be used outside service area.
Undetect (U)SIM	USIM Card is not installed. Install and try again.
Not input PIN	Is PIN Authentication active? Enter PIN.
PUK Code is locked, please configure the dial info.	USIM Card is completely inaccessible because incorrect PUK Code was entered ten consecutive times. Contact SoftBank Mobile Customer Center, General Information (P.7-3).



Appendix	7-2
Specifications.....	7-2
Warranty & Service.....	7-2
Customer Service	7-3

Specifications

Model Name	004Z
Dimensions	87 mm (D) × 27 mm (W) × 14 mm (H)
Weight*	29 g
Interface	USB 2.0
	microSD Card or microSDHC Card
Power Consumption*	Maximum: 2.9 W Normal: 1.9 W Standby: 0.25 W
Operating Environment	Operating Temperature: -10 to +60 Operating Humidity: 5% to 95%
Frequency	W-CDMA: 1500 MHz, 2100 MHz GSM: 850 MHz, 900 MHz, 1800 MHz, 1900 MHz
Compatible Networks	ULTRA SPEED (HSPA+/DC-HSDPA)/ 3G high speed (HSUPA/HSDPA)/ 3G (W-CDMA)/ GSM/EDGE/GPRS

*Approximate value

Warranty & Service

Modem purchase includes Warranty.

- Confirm shop name and purchase date.
- Read contents of Warranty and keep it in a safe place.
- The warranty period can be found in the Warranty.
- When submitting modem for repair, contact SoftBank Mobile Customer Center, General Information (P.7-3) or the nearest SoftBank Shop; be prepared to describe problem in detail.
- During the warranty period, repairs will be made under the terms and conditions described in the warranty.
- After the warranty period, repairs will be upon request; if said repairs can be made, you will be charged for them.

- SoftBank Mobile is not liable for any damages resulting from the use of this modem.
- Modem files and settings may be lost or altered due to accidents or repairs. Keep a copy of important files, etc. SoftBank Mobile is not liable for damages resulting from accidental loss or alteration of modem files or settings.
- Disassembling or modifying this modem may be a violation of the Radio Law. Note that SoftBank Mobile does not accept repair requests for disassembled or modified products.
- MAC address may be changed due to accidents or repairs.
- For more details, please visit your nearest SoftBank Shop or contact SoftBank Mobile Customer Center, General Information (P.7-3).

Customer Service

For information about SoftBank Mobile products or services, call General Information.
For repairs, call Customer Assistance.

SoftBank Mobile Customer Center

General Information

- From a SoftBank handset, dial toll free at 157
- From a landline/IP phone, dial toll free at 0800-919-0157

Customer Assistance

- From a SoftBank handset, dial toll free at 113
- From a landline/IP phone, dial toll free at 0800-919-0113

If you cannot reach a toll free number, use the number (charges apply) below for your service area:

Hokkaido Area Tohoku Area Hokuriku Area Kanto, Koshinetsu Area	022-380-4380	Tokai Area	052-388-2002
Kansai Area	06-7669-0180	Chugoku, Shikoku Area Kyushu, Okinawa Area	092-687-0010

Data Communications Support Center (Call for Setup or Operation Information)

Service Hours 9:00-20:00

From a SoftBank handset, dial toll free at 5525

From a landline/IP phone, dial toll free at 0088-21-5525

*These numbers cannot be dialed from outside Japan.

SoftBank Mobile Global Call Center

From outside Japan, dial +81-3-5351-3491 (toll free from SoftBank handsets)

If 004Z is lost/stolen, call this number immediately (international charges apply)

ZTE Japan Customer Support Webpage

http://www.zte.co.jp/products/devices/devices_gallery/

SoftBank 004Z User Guide

February 2011, First Edition

SOFTBANK MOBILE Corp.



モバイル・リサイクル・ネットワーク
携帯電話・PHSのリサイクルにご協力を。

Please help the mobile industry maintain high environmental standards. Recycle your old handsets, batteries and charger units (all manufacturers and brands). Before you recycle, please remember these important points:

- Handsets, batteries and chargers submitted for recycling cannot be returned.
- Always erase all data on old handsets (Phone Book entries, call records, mail, etc.).

Model Name: SoftBank 004Z

Manufacturer: ZTE Corporation
